



Postbus 17
7480 AA Haaksbergen
E-mail: ihb@ihbinternational.nl
Web: www.ihbinternational.nl

Tel. + 31 (0)53 57 431 43
Mob. + 31 (0)63 01 548 26
Fax + 31 (0)84 87 266 72

BTW nr. 1014.51.556.B.02

YANMAR D27 & 36 diesel BB motoren / outboard motors / Außenbordmotoren

€ 10,450.-	Yanmar D27	prijs / price	
€ 13,000.-	Yanmar D36		
Code 1824-1 & 2		excl.	TRANSPORT / BTW / VAT/as is where is
Omschrijving/description	CAT A	UK	

Wij hebben 2 Yanmar **diesel** buitenboordmotoren beschikbaar. De motoren zijn in goede staat en goed onderhouden.

We have 2 Yanmar **diesel** outboard motors available. The motors are in good condition and are well maintained.

Wir haben 2 Yanmar **diesel** Außenbord-Motoren verfügbar. Die Motoren sind Funktionsfähig und gut gewartet.

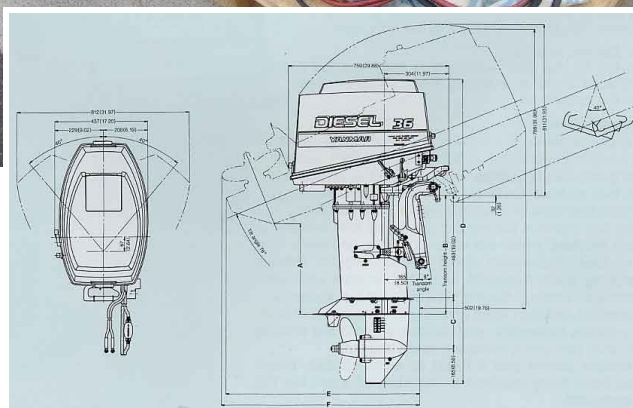



Specifications D27

Model: Yanmar D27 Diesel Outboard
 Type: Vertical crankshaft, 4 cycle
 Cooling: water cooled diesel engine
 Maximum output/RPM: 27hp (19.9KW) at 4,500 rpm
 Dry weight: 181 pounds
 Fuel: Diesel, kerosene + oil, or biodiesel
 Bore and stroke: 3 - 70x70mm (808cc)
 Combustion system: Direct injection (by unit)
 Number of cylinders: 3
 Valve Driving: Timing-belt driven/OHC system
 Cooling: Direct seawater cooling
 Starting: Electric or emergency recoil rope
 Steering system: Tiller (bar handle)
 Speed control system: Tiller (bar handle)
 Tilt up system = Manual with spring assist
 Gear reduction ration: 1.846 (both forward and reverse)
 Clutch: Dog type, by clutch lever operation
 Propeller: 3-blade, spline coupling
 Engine lubrication: Forced lubrication pump
 Lower unit lubrication: oil bath
 YOM: 1997



Postbus 17
7480 AA Haaksbergen
E-mail: ihb@ihbinternational.nl
Web: www.ihbinternational.nl

Tel. + 31 (0)53 57 431 43
Mob. + 31 (0)63 01 548 26
Fax + 31 (0)84 87 266 72

BTW nr. 1014.51.556.B.02



Specifications Yanmar D36

Maximum output: 36 hp
Tilt system: Manuel
Weight: 116 kg
Displacement: 1109 cc
Number of cylinder: 3
Cooling system: direct seawater
Combustion system: direct injection
Starting system: Electric with emergency rope
YOM 1995