



Postbus 17  
7480 AA Haaksbergen  
E-mail: [ihb@ihbinternational.nl](mailto:ihb@ihbinternational.nl)  
Web: [www.ihbinternational.nl](http://www.ihbinternational.nl)

Tel. + 31 (0)53 57 431 43  
Mob. + 31 (0)63 01 548 26  
Fax + 31 (0)84 87 266 72

BTW nr. 1014.51.556.B.02

## Gerhard Schubert GmbH

### Inpakmachine/Packaging line/Verpackungsanlage

€	-	prijs per stuk / each		
On request		totaalprijs / total amount	prijs / price	
Code 1820-1			excl.	TRANSPORT / BTW / VAT/as is where is
Omschrijving/description	CAT A	NH		

Wij hebben een complete verpakkingslijn beschikbaar die is ingezet voor de verpakking van computeronderdelen. De voormalige eigenaar is 's werelds grootste computerchip fabrikant. Bouwjaar 2004 en begin 2005 is de lijn in productie genomen. De lijn is eind 2008 stop gezet omdat de verpakkings- activiteiten uitbesteed werden. Alle technische gegevens manuals e.d. zijn beschikbaar.

We have a complete packaging line available originally used for packaging of computer parts. The line was formally owned by world largest chip manufacturer. Manufacturing date end 2004 and installation date beginning of 2005. The line was in production until the end of 2008. All manuals, data are available.

Wir haben eine Verpackungslinie verfügbar für die Verpackung von Computerteile. Der ehemalige Besitzer ist der weltweit grösste Computerchip Produzent. Baujahr ist 2004 und in 2005 ist die Anlage in betrieb genommen. Bereits in 2008 ist die Anlage wegen eine Reorganisation aus Betrieb genommen. Alle Daten, Handbücher usw. sind verfügbar.



Video available on:



<http://www.youtube.com/watch?v=IIUsiHLomJA>

Industriële Handels Bemiddeling voor o.a.:

Machines • Incurante voorraden • Magazijninventarissen • Kantoorinventarissen • Fabrieksinrichtingen • Bouwmaterialen • Grondstoffen • Etc.

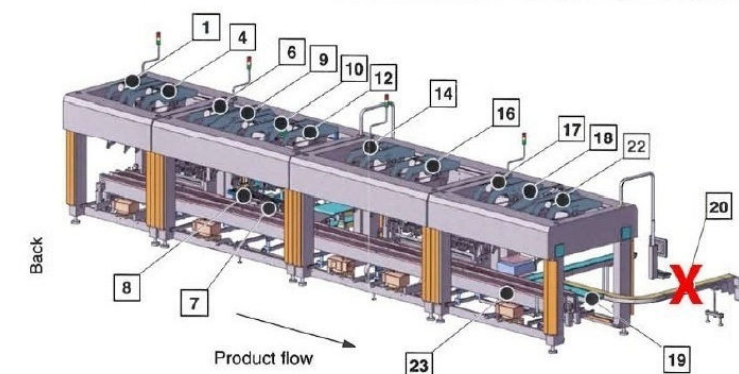

### Front section

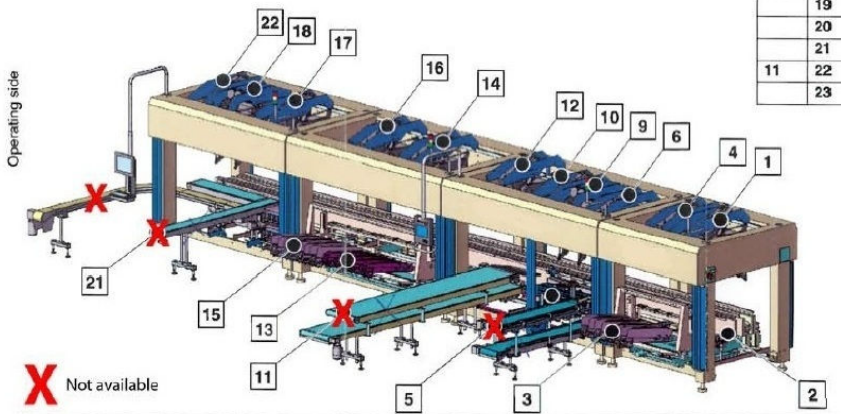

**X** Not available

903457\_en\_A3\_V3.fm

Intel No.	Sequence No.	Unit Designation
1	1	TLM-F2/1 robot "product carrier I infeed"
1.1	2	Vacuum conveyor for cassette supply - Puk
2.1	3	Magazine Thermoform tray lower section
2	4	TLM-F2/2 robot "Thermoform tray placing"
3.1	5	Infeed conveyor "Jedec tray magazine" with light curtain
3	6	TLM-F2/3 robot "Jedec tray destacking"
	7	NC pusher stack
4.1	8	CPU collator desk (positioning unit) and turning unit
4	9	TLM-F2/4 robot "CPU picking"
5	10	TLM-F2/5 robot "CPU placing"
6.1	11	Infeed conveyor (generic tray magazine) for FHS tray
6	12	TLM-F2/6 robot "FHS loading"
7.1	13	Magazine and presentation unit for CPU lid magazine
7	14	TLM-F2/7 robot "CPU lid placing"
8.1	15	Magazine and presentation unit for Thermoform lids
8	16	TLM-F2/8 robot "Thermoform lid placing"
9	17	TLM-F2/9 robot "welding"
10	18	TLM-F2/10 robot "Thermoform handling"
	19	Conveyor belt for product discharge
	20	Reject #1 (slat chain conveyor for rework)
	21	Rework Station #1 (infeed conveyor for rework)
11	22	TLM-F2/11 robot "product carrier I refeed"
	23	Vacuum conveyor for cassette return

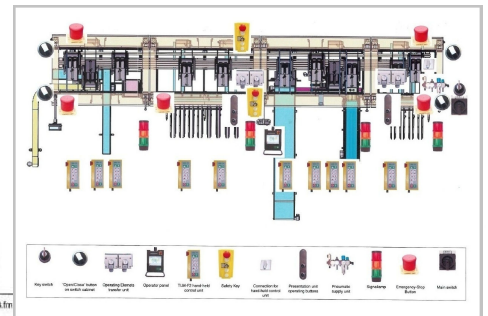

SCHUBERT Tray Loader Robot Enclosure 2.0M by 2.0M with 4 station loading magazine, Becker Vacuum Pump, 2 x SNC-F2 Controllers, 2M Shuttle Conveyor Schubert TLM-F2, 2 Axis robot with 6 Suction Head, Schubert TLM-F2 2 Axis robot with 4 Vacuum Head.

SCHUBERT Robot Enclosure 2.0M by 3.0M, BEKA Vacuum Pump, 7 Sensor Shuttle Conveyor, Pesto Vacuum Loader, 3 x SNC-F2 Conbtrollers, 1 Touchscreen Controller, Schubert TLM-F2 2 Axis robot with 24 Station Part Placer, Schubert TLM-F2 2 Axis robot with 4 Station Part Placement Head, Schubert TLM-F2 2 Axis robot with 4 Station Grab Head, Schubert TLM-F2 2 Axis robot with 4 Station Grab Head.

SCHUBERT Robot Enclosure 2.0M by 3.0M with 4 station loading magazine, 2 x Becker Vacuum Pumps (Mod D 80 BY 4 P, 0.9Kw), Shuttle Conveyor, TIPS Inspection System, 2 x SNC-F2 Controllers, Schubert TLM-F2 2 Axis robot with 4 Station Suction/Vacuum Head, Schubert TLM-F2 2 Axis robot with 4 Station Suction/Vacuum Head.

SCHUBERT Robot Enclosure 2.0M by 3.0M with 4 station loading magazine with Branson Digital Compact Ultrasonic Weld Source, 1 x Becker Vacuum Pump and Entuitive Touch Monitor, 3 x SNC-F2 Controllers, Schubert TLM-F2 2 Axis robot with 16 Station Ultrasonic Welding head, Schubert TLM-F2 2 Axis robot with 4 Station Placement Head, Schubert TLM-F2 2 Axis robot with 6 Station Suction/Vacuum Head.

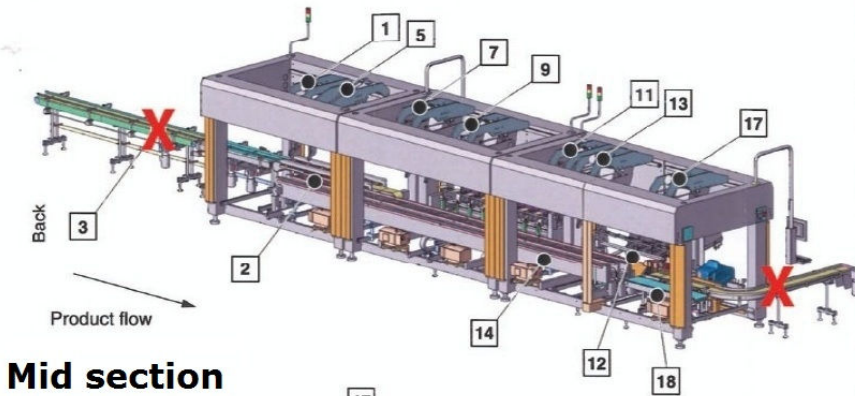

Mid section

Intel No.	Sequence No.	Unit Designation
12	1	TLM-F2/12 robot "product carrier II infeed"
12.1	2	Vacuum conveyor for cassette supply - Puk
	3	Conveyor belt for product infeed
	4	Grouping chain
13	5	TLM-F2/13 robot "welded Thermoform placing"
14.1	6	Flyer magazine and presentation unit
14	7	TLM-F2/14 robot "flyer placing"
15.1	8	Opkit magazine and presentation unit
15	9	TLM-F2/15 robot "opkit placing"
16.1	10	Carton magazine and presentation unit
16	11	TLM-F2/16 robot "carton erecting"
17.1	12	Centering unit
17	13	TLM-F2/17 robot "Carton loading and product carrier II refeed"
	14	Vacuum conveyor for cassette return
	15	Vacuum conveyor 2
	16	Gluing station
18	17	TLM-F2/18 robot "carton closing and transfer"
	18	Conveyor belt for product discharge
	19	Reject #2 (slat chain conveyor for rework)

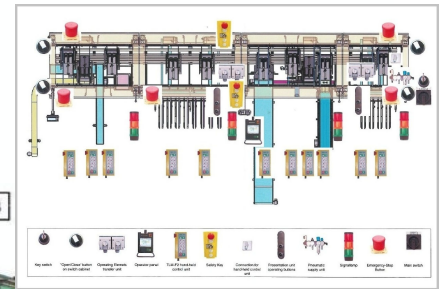
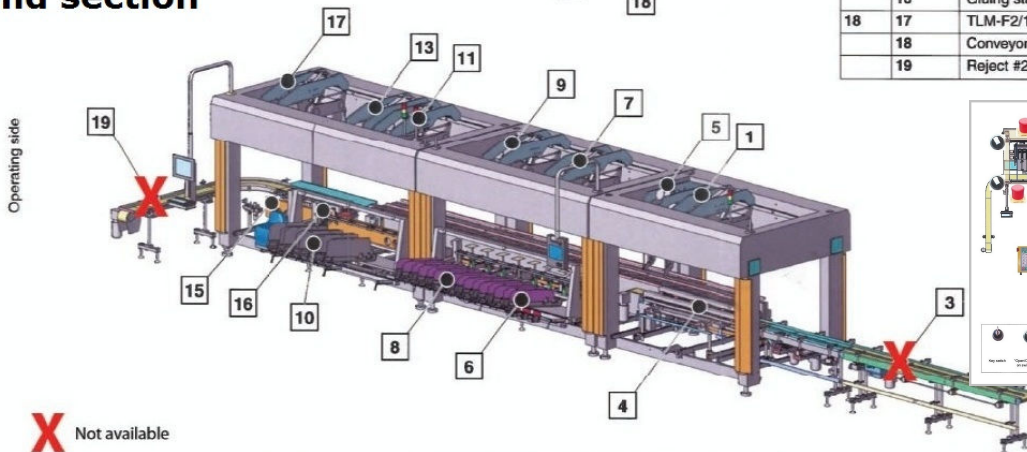

SCHUBERT Robot Enclosure 2.5M by 2.0M with 2 x SNC-F2 Controllers, Becker Vacuum Pump, 2 x Materials Handling Conveyors, Schubert TLM-F2 2 Axis robot with 6 x Station Suction/Vacuum Head, Schubert TLM-F2 2 Axis robot with 4 x 8 Station Parts Manipulator.

SCHUBERT Robot Enclosure 3.0M by 2.0M with 4 Station Magazine Loader, Touch Screen Controller, 1 x SNC-F2 Controller, 2 x Becker Vacuum Pumps, Schubert TLM-F2 2 Axis robot with 4 Station Intelligent Suction/Scanning Heads and 2 x Accu-Sort EM50 Scanner Expansion Modules, Shuttle Conveyor Schubert TLM-F2 2 Axis robot with 4 Station Intelligent Suction/Scanning Heads and 2 x Accu-Sort EM50 Scanner Expansion Modules, Shuttle Conveyor.

SCHUBERT Dual Robot Enclosure 4.0M by 2.0M, Entuitive Touchscreen Monitor, 3 x SNC-F2 Controllers, Nordson Pro-Blu 7 Printer, 2 x Becker Vacuum Pumps, Shuttle Conveyor, VeriTec G-Net Verification System, 4 Slot Magazine Schubert TLM-F2 2 Axis robot with 4 x 4 Vacuum Handlers, Schubert TLM-F2 2 Axis robot 4 Station Handling Devices, Schubert TLM-F2 2 Axis robot with 4 Station Material Handlers.

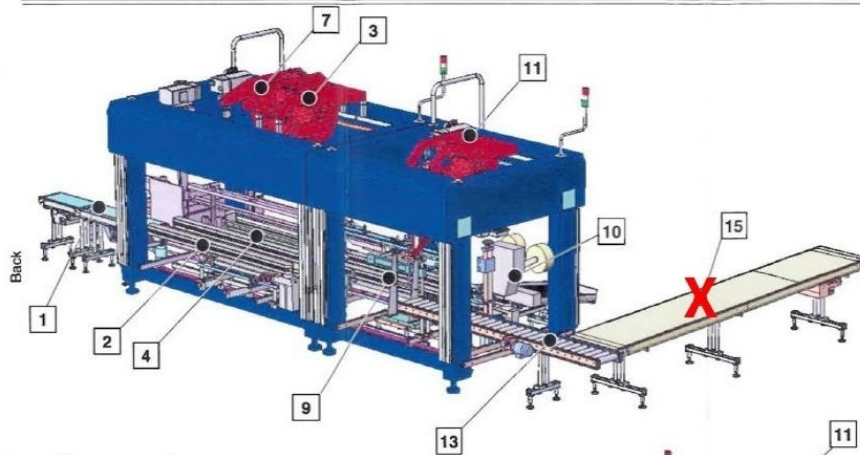

Intel No.	Sequence No.	Unit Designation
	1	Product infeed conveyor
	2	Grouping chain
19	3	TLM-F2/2 robot "transfer unit" (Carton Grouping)
	4	Grouping table
	5	Carton erector (K1)
	6	Centering unit
20	7	TLM-F2/1 robot "filler" (Disti Box Loading)
	8	Chain conveyor
	9	Closing unit
	10	Pago labeler
21	11	TLM-F2/3 robot "transfer unit" (Disti Box Transfer)
	12	Camera system
	13	Roller conveyor
	14	Rejection station (3rd Reject)
	15	Conveyor belt

### Back section

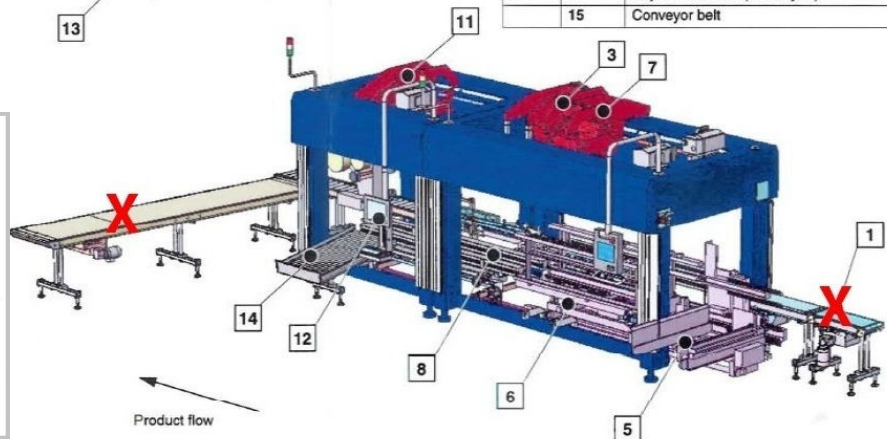
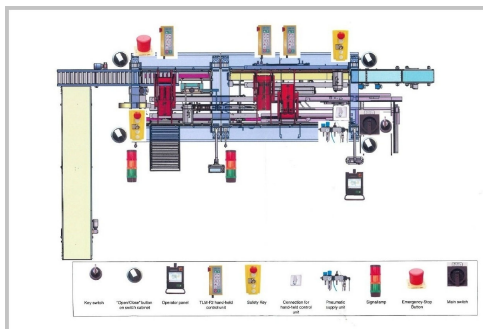

903456\_en\_AB\_A3\_V3.fm 07/2008

17

SCHUBERT Robot Enclosure 3.0M by 2.0M with Touchscreen PC, 2 x SNC-F2 Controllers, 2 x Becker VT 425 Vacuum Pumps, Schubert TLM-F2 2 Axis robot with 5 Station Materials Handling Head, Schubert TLM-F2 2 Axis robot with 5 Station Materials Handling Head.

Robot Enclosure 2.0M by 2.0M with Entuitive Touchscreen Moniator, Box Taping HeadSchubert TLM-F2 2 Axis robot with 16 Vacuum Stations, Pago PagoMat 15 1106T Labeller/Printer.

Palletlift EURODRIVE R87DT90S4-BMG With safety guards and SEW Motor.

### Small (spare) Parts:

SCHUBERT 4 Station Suction Head incl trolley

SCHUBERT 4 Station Suction Head

SCHUBERT 8 Station Part Placement Head incl trolley

SCHUBERT 4 Station Part Placement Head

SCHUBERT 3 Station Placement Head

SCHUBERT 4 Station Suction Head

2x steel trolley: equipped with spare parts for the loading system